

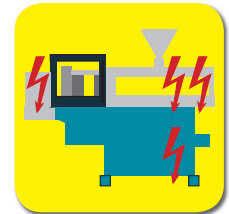

Spritzgiessautomaten

Innovative into the Future – BOY-Injectioneering



BOY *Electric*

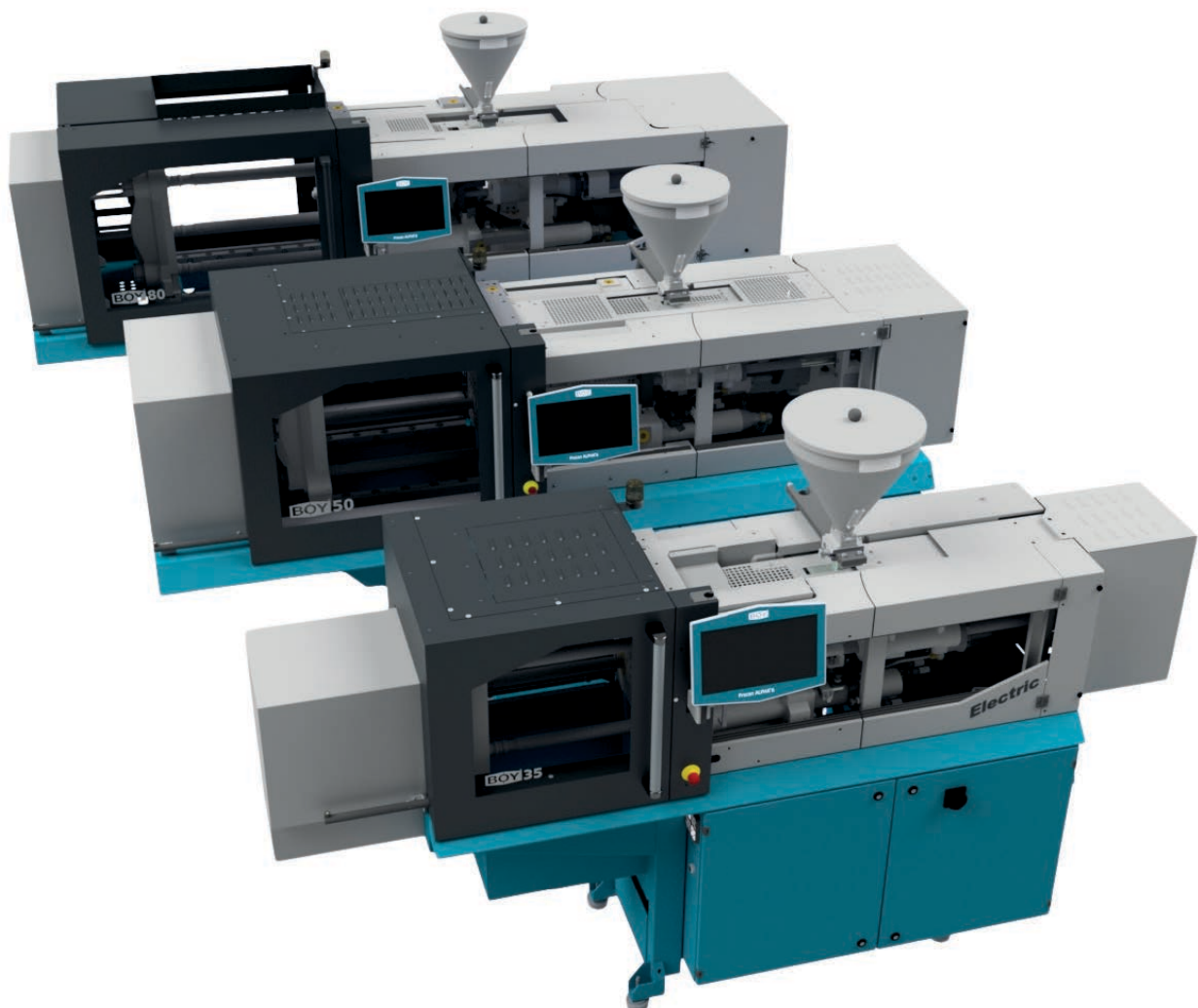

Injection moulding machines BOY 35 *Electric*
BOY 50 *Electric*
BOY 80 *Electric*

The new BOY

- 1 Lubricant-free mould installation area.



E-Ejector



- 5 The trip chute, which is accessible from three sides, allows easy removal of the injection moulded parts.

Electric series

- 2** State-of-the-art and intuitive Procan ALPHA® 6 machine control.

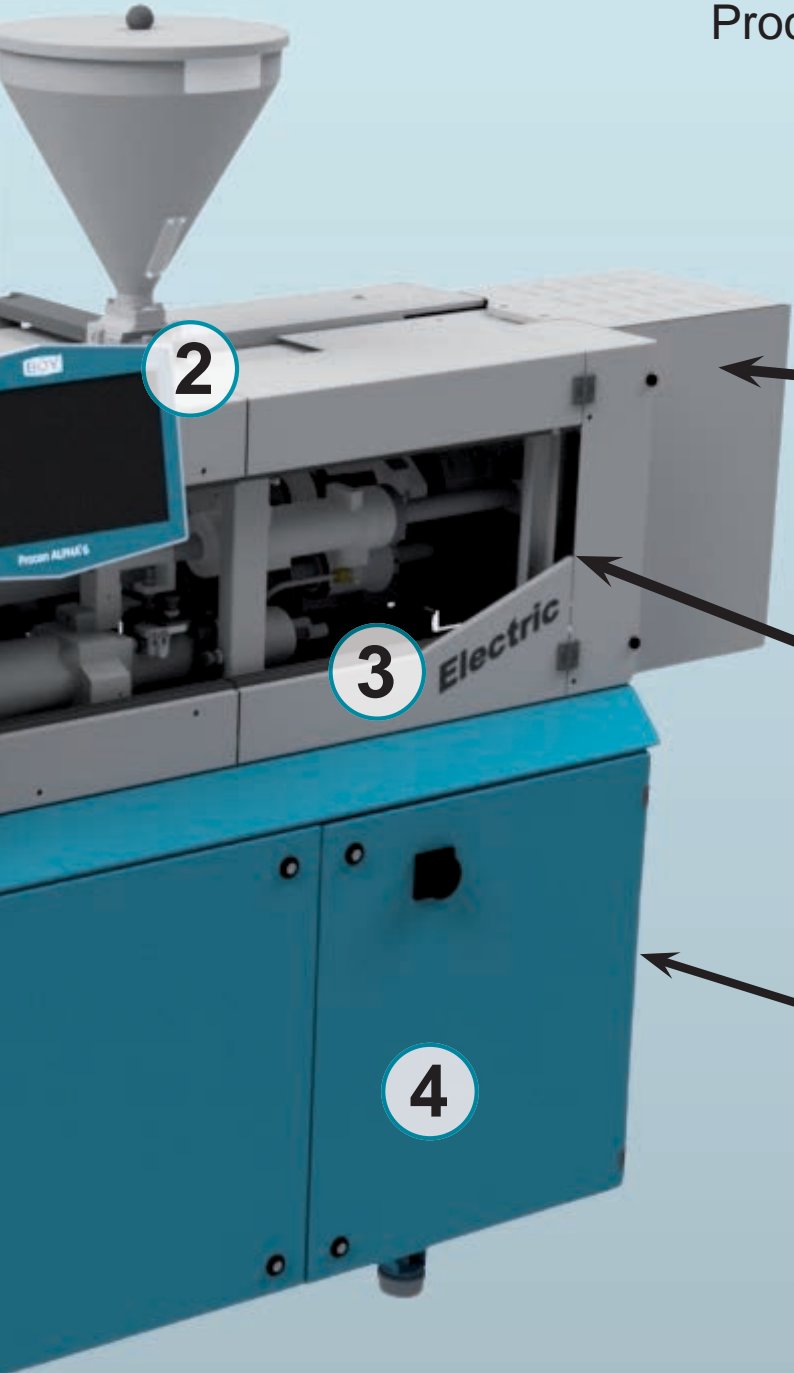

E-Dosing



E-Injection



Servo-Drive

- 3** Completely redesigned safety enclosure with fully openable safety door.

- 4** Stable and compact machine construction.

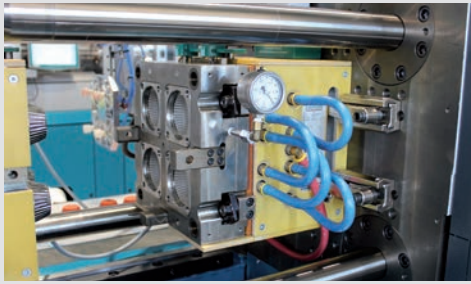

Large distances between piston-pillar and platens for holding larger moulds

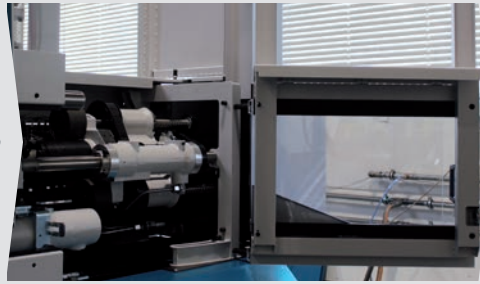

Easily accessible plasticising unit

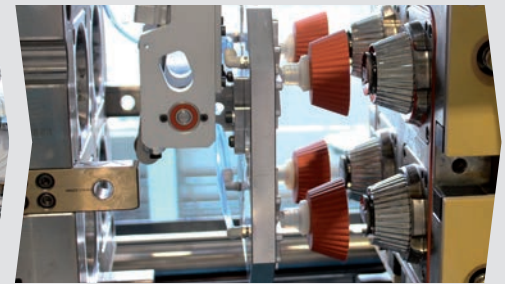

Synchronisation of the movements of LR 5 and electric ejector

- **Parallel movement without double pump**
- **Compactness of a two-platen machine**
- **Highly dynamic injection unit**
- **Lubricant-free tool installation area**
- **Improved synchronised movement during ejection**
- **Parallel clamping force build-up for injection**
- **Highest positioning accuracy**
- **Possibility to actively brake**

BOY Electric: Proven rethought

In addition to the proven and energy-saving servo-hydraulic machines of the established E series, our portfolio now also includes the BOY Electric series in the 350-800 kN clamping force range.

The BOY Electric therefore offers all the advantages of an all-electric injection moulding machine in terms of high dynamics and parallel movements. For example, the drives for injection, dosing and ejector on a BOY Electric are realised electromechanically.

The electromechanical universal injection unit has been redesigned and significantly enhanced for the BOY Electric series. The new type of dynamic pressure measurement is unique in the field of injection moulding machines and a patent has already been granted. The force transmitted to the screw is recorded at the injection mechanism by means of a force sensor and analysed in the machine control system.

The electromechanical drive technology offers additional benefits in the form of even more precise position detection, dynamic movement sequences and shorter cycle times thanks to parallel clamping force build-up for injection.

The proven two-platen clamping unit with the oil and lubricant-free mould installation space is supplied by the established and energy-saving servo-hydraulics. Together with the pressure intensifier and differential pressure technology, hydraulic pressure is converted dynamically into the clamping platen movement and energy-efficiently into the clamping force.

The new electromechanical ejector exceeds the dynamics of its hydraulic counterpart: thanks to its even more precise position detection and very direct control, parallel, precise and highly dynamic movements can be realised in conjunction with clamping platen or handling movements. These not only save cycle time in individual cases, but also protect the product as well as the mould, gripper and machine. The electromechanical ejector also has a major advantage with extremely slow movements, as the stick-slip effects that can occur in the hydraulic system are avoided.

The BOY Electric series has also been given a new machine design, which is not only characterised by its new look. The drive and inverter technology is integrated in the smallest possible space and still allows for numerous expansion options. A new, compact and low-maintenance safety technology is now also finding its way into the BOY injection moulding machines. This OSSD (Output Signal Switching Device) technology enables very user-friendly monitoring at the highest safety level. By systematically integrating the high-performance technology into the BOY Electric, BOY remains true to its philosophy of minimising the footprint.

BOY 35 Electric

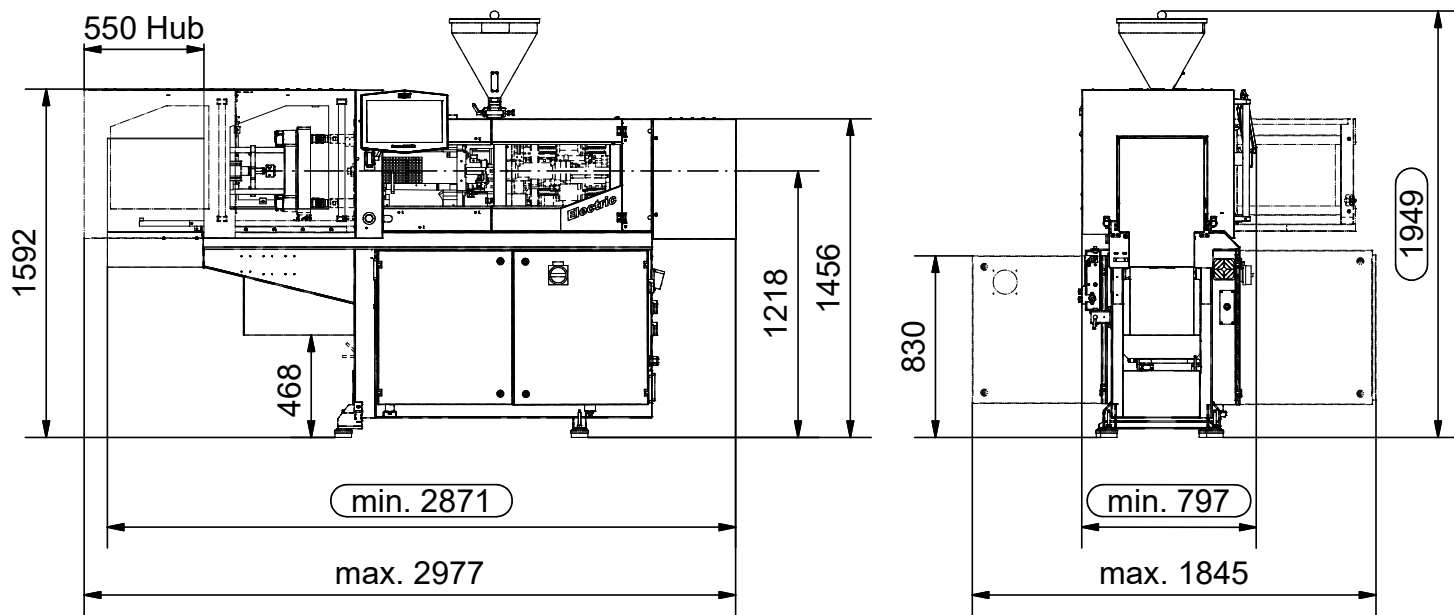

Technical Data – standard version

Injection unit for processing thermoplastics		SP 96						
Screw diameter	mm	12	14	18	22	24	28	32
Screw- L/D-ratio		18	18	20	17.5	22	18.6	16.3
Max. stroke volume (theoretical)	cm ³	4.5	6.1	20.4	30.4	43	58.5	76.5
Max. shot weight in PS (theoretical)	g	4.1	5.6	18.6	27.7	39.1	53.2	69.5
Injection volume flow (theoretical)	cm ³ /s	18.9	25.7	42.5	63.5	75.5	102.8	134.3
Injection speed (theoretical)	mm/s	167						
Max. spec. injection pressure	bar	2450	2413	2587	2655	2231	1639	1255
Max. screw stroke	mm	40	40	80	80	95	95	95
Nozzle force / contact pressure	kN	48						
Nozzle retraction stroke	mm	205						
Screw torque	Nm	50	75	130	180	200	200	200
Screw speed (infinitely variable)	U/min.	400						
Screw pulback force	kN	22.2	30	30	30	44	44	44
Heating power (nozzle + cylinder)	W	2200	2560	3250	3550	5800	5800	5800
Hopper capacity	litre	7.5	7.5	13	13	20	20	20

Clamping unit	
Clamping force	kN 350
Distance between tie bars	mm (h x v) 280 x 254
Max. daylight between platen	mm 500
Max. opening stroke (adjustable)	mm 300
Min. mould height	mm 200
Max. mould weight on moveable clamping side	kg max. 220 / from 150
Mould opening force	kN 29.5
Mould closing force	kN 21.4
Ejector stroke (max.)	mm 150
Ejector force pushing / pulling	kN 10

General	
Installed driving power / total power	kW 28.2
Duration of the dry cycle (EUROMAP 6)	s – mm 1.5 – 196
Hydraulic system pressure	bar 210
Oil tank capacity	litre 35

Dimensions and weights	
Dimensions (LxWxH) / Footprint	mm / m ² 2871 x 797 x 1949 / 2.29
Total weight net (without oil)	kg 1400
Total weight gross (pallet & foil / wooden case)	kg 1475 / 1650
Transport dimensions / case (LxWxH) approx.	m 3.0 x 1.06 x 2.1 / 3.0 x 1.06 x 1.8

BOY 50 Electric

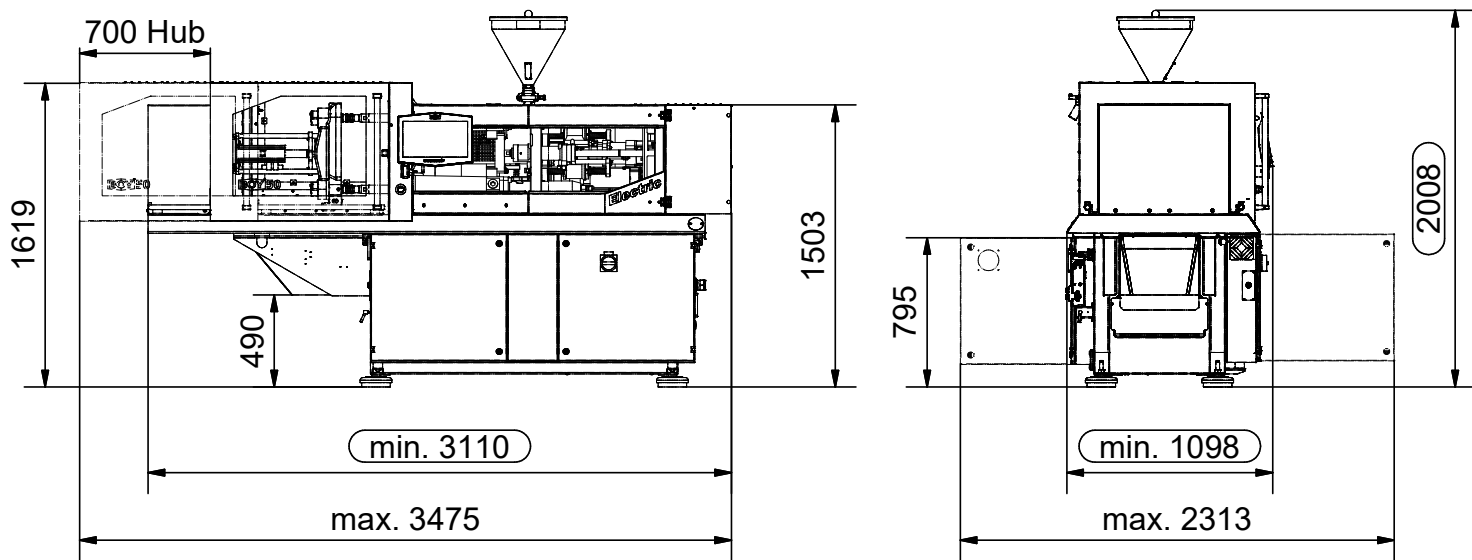

Technical Data – standard version

Injection unit for processing thermoplastics		SP 96						
Screw diameter	mm	12	14	18	22	24	28	32
Screw- L/D-ratio		18	18	20	17.5	22	18.6	16.3
Max. stroke volume (theoretical)	cm ³	4.5	6.1	20.4	30.4	43	58.5	76.5
Max. shot weight in PS (theoretical)	g	4.1	5.6	18.6	27.7	39.1	53.2	69.5
Injection volume flow (theoretical)	cm ³ /s	18.9	25.7	42.5	63.5	75.5	102.8	134.3
Injection speed (theoretical)	mm/s	167						
Max. spec. injection pressure	bar	2450	2413	2587	2655	2231	1639	1255
Max. screw stroke	mm	40	40	80	80	95	95	95
Nozzle force / contact pressure	kN	48						
Nozzle retraction stroke	mm	205						
Screw torque	Nm	50	75	130	180	200	200	200
Screw speed (infinitely variable)	U/min.	400						
Screw pulback force	kN	22.2	30	30	30	44	44	44
Heating power (nozzle + cylinder)	W	2200	2560	3250	3550	5800	5800	5800
Hopper capacity	litre	7.5	7.5	13	13	20	20	20

Clamping unit		
Clamping force	kN	500
Distance between tie bars	mm (h x v)	360 x 335
Max. daylight between platen	mm	650
Max. opening stroke (adjustable)	mm	400
Min. mould height	mm	250
Max. mould weight on moveable clamping side	kg	max. 400 / from 250
Mould opening force	kN	38
Mould closing force	kN	24.4
Ejector stroke (max.)	mm	150
Ejector force pushing / pulling	kN	10

General		
Installed driving power / total power	kW	28.8
Duration of the dry cycle (EUROMAP 6)	s – mm	1.9 – 252
Hydraulic system pressure	bar	180
Oil tank capacity	litre	49

Dimensions and weights		
Dimensions (LxWxH) / Footprint	mm / m ²	3110 x 1097 x 2008 / 3.41
Total weight net (without oil)	kg	2600
Total weight gross (pallet & foil / wooden case)	kg	2700 / 3000
Transport dimensions / case (LxWxH) approx.	m	3.43 x 1.15 x 2.05 / 3.43 x 1.15 x 1.95

BOY 80 Electric

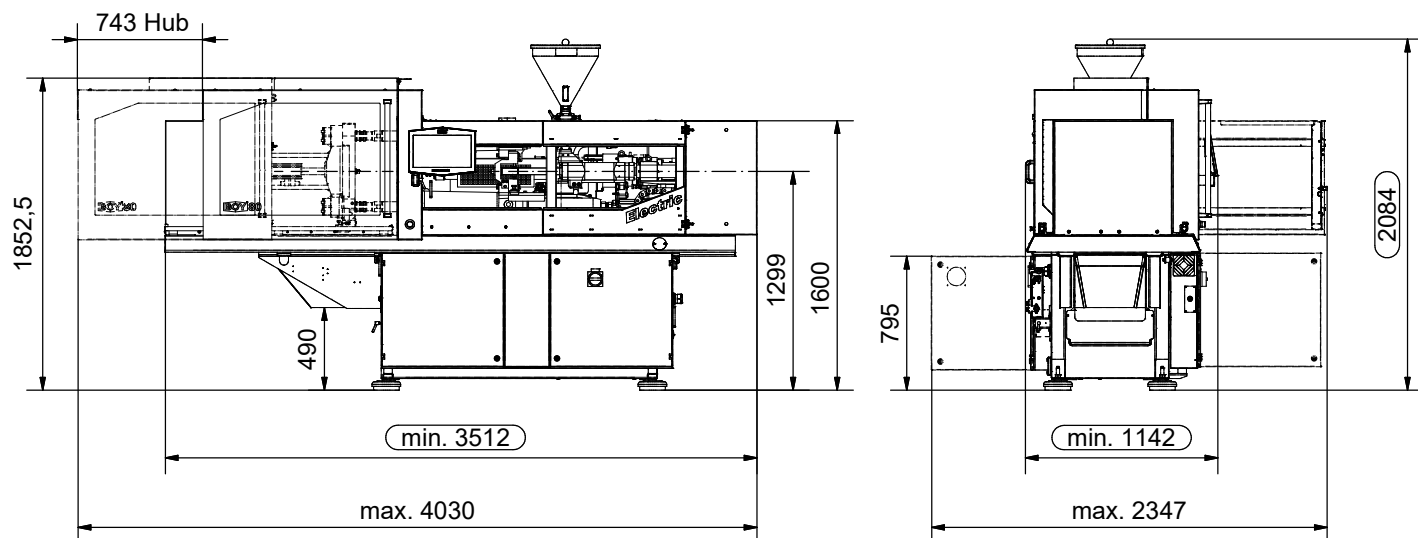

Technical Data – standard version

Injection unit for processing thermoplastics		SP 170			
Screw diameter	mm	28	32	38	42
Screw- L/D-ratio		22.7	20	16.7	15
Max. stroke volume (theoretical)	cm ³	76.9	100.5	141.8	173.2
Max. shot weight in PS (theoretical)	g	70	91.4	129	157.6
Injection volume flow (theoretical)	cm ³ /s	92.4	120.6	170.1	207.8
Injection speed (theoretical)	mm/s	150			
Max. spec. injection pressure	bar	2210	1692	1203	982
Max. screw stroke	mm	125			
Nozzle force / contact pressure	kN	48			
Nozzle retraction stroke	mm	215			
Screw torque	Nm	300			
Screw speed (infinitely variable)	U/min.	400			
Screw pulback force	kN	66			
Heating power (nozzle + cylinder)	W	7700			
Hopper capacity	litre	20			

Clamping unit		
Clamping force	kN	800
Distance between tie bars	mm (h x v)	430 x 360
Max. daylight between platen	mm	725
Max. opening stroke (adjustable)	mm	475
Min. mould height	mm	250 (425)
Max. mould weight on moveable clamping side	kg	max. 500 / from 300
Mould opening force	kN	57.8
Mould closing force	kN	41.2
Ejector stroke (max.)	mm	150
Ejector force pushing / pulling	kN	10

General		
Installed driving power / total power	kW	51.2
Duration of the dry cycle (EUROMAP 6)	s – mm	2.1 – 301
Hydraulic system pressure	bar	180
Oil tank capacity	litre	49

Dimensions and weights		
Dimensions (LxWxH) / Footprint	mm / m ²	3512 x 1142 x 2084 / 4.01
Total weight net (without oil)	kg	3300
Total weight gross (pallet & foil / wooden case)	kg	3420 / 3800
Transport dimensions / case (LxWxH) approx.	m	3.95 x 1.2 x 2.2 / 3.98 x 1.28 x 2.05



E-Injection



E-Dosing



E-Ejector



Procan ALPHA® 6

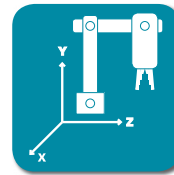

Automation



Servo-Drive



The specified efficiency classification is achievable depending on the respective machine equipment.

Equipment

Injection unit		Electronics	
Pivoting injection unit	■	USB interface for access and data exchange	■
Preset screw speed values with ramping transition	■	Interface kit: Serial/Temperature device, USB/Printer and Ethernet	□
Cold start protection	■	OPC interface	□
Number of set points of injection speed	8	4 freely programmable inputs/outputs	□
Number of set points of injection pressure	2	Piece counter	■
Start of holding pressure dependent on hydraulic pressure, stroke and time	■	Preselect cycle counter with auto shut-off	■
Start of holding pressure, cavity pressure-dependent	□	Grounded socket outlet 230 V ~ / 10 A (alternatively can be switched off)	■(□)
Number of set points of holding pressure	8	CEE socket outlet 400 V ~ / 16 A (alternatively can be switched off)	■(□)
Production monitoring at start of holding pressure	■	Socket distributor 3 x 400 V ~ / 3 x 230 V ~ switched (separate feed line required)	□
Closed loop control for the complete injection profile and back pressure	■	Energy distributor with four fixed connections, up to 5 x 400 V CEE + 3 x 230 V (sockets can be switched off optionally). Standard supply 125 A / 5 x 50 mm²	□
Control for intrusion-injection	■	Switch cabinet ventilation	■
PID microprocessor-controlled heating zones for cylinder + nozzle set and temp. display	5	Standardized interface for handling units (EUROMAP 67)	□
Hydraulically actuated needle shut-off nozzle (pneumatic for XS-LSR)	○	Separate feeder (heating and motor current)	○
Hopper quick discharge	■	7-day timer	■
Automatic material loader / feeder	□	Additional temperature control	□
Adjustable nozzle force	■	Brush control	□
Delayed nozzle retraction	■	Connector for safety switch to inhibit mould closing	□
Servo-electric screw drive (separate feed line required)	■	Integrated hot runner control, 8/16-fold (separate feed line required)	□
High wear-resistant plasticizing units	○	Air conditioning unit for control cabinet	□
High wear-resistant EconPlast unit	○	Alarm signal with sound	□
Simultaneous injection to build up clamping force	■		
Clamping unit		Hydraulics	
Reduced mould height by 50 mm	□	Servo-motor pump drive (Servo-drive)	■
Moving platen support to improve the precision when using large moulds	■	Oil preheating circuit automatic	■
Number of set points of mould closing speed / opening speed	8/8	Oil temperature gauge / Controlled oil cooling / Oil level indicator	■
Number of reopening attempts after mould closing	■	Proportional valve with stroke feedback and positioning action for clamp unit (only for the BOY 50 <i>Electric</i> and BOY 80 <i>Electric</i>)	■
Hydr. ejector with dig. adjustable pressure, speed, position + no. of strokes, intermediate stop position	■		
Hydraulic ejector with adjustable stroke 150 mm	■	General	
Hydraulic unscrewing device, one or two directions of rotation with intermediate stop	□	Cooling water distributor with electric shut-off valve for injection mould	○
Hydraulic unscrewing device, two directions, proportional valve and pulse generator	□	Temperature control for feed throat	□
Core pull control with 4/3 way directional control valve and freely selectable operational programmes	□	6- / 8-zone water distributor	○
Injection compression (coining) and breathing with mould degassing control	□	Tool kit	□
Hydraulic guard safety device	■	Spare parts package	□
Self adjusting mechanical drop bar safety system with electronic monitor	□	Oil filling	□
Safety gate for handling devices	■	Anti-vibration mounts	■
Electronically operated safety gate	○		
Selection flap	○		
Air ejection	□		
Mould lifting crane	□		
Simultaneous ejector movement (with double pump)	■		
Integrated sprue picker	□		

■ standard ○ alternatively □ optional – not available

You would like to learn more about this BOY injection moulding machine?

Data and Equipment (complete overview)



competence brochure



Dr. Boy GmbH & Co. KG
Industriegebiet Neustadt / Wied
Neschener Str. 6
53577 Neustadt-Fernthal
Germany

Phone: +49 2683 307-0
E-Mail: info@dr-boy.de
Internet: www.dr-boy.de



BOY-APP
free of charge at
http://app.dr-boy.de

